

# Architectures of the Interworking of 3G Cellular Networks and Wireless LANs

**Maode Ma**

*Nanyang Technological University, Singapore*

## INTRODUCTION

Recent development on the wireless networks has indicated that IEEE 802.11.x standards based **wireless LAN** and third-generation cellular wireless networks such as CDMA2000 or **UMTS** (i.e., WCDMA) could be integrated together to offer ubiquitous Internet access to end users. The two technologies can offer functions that are complementary to each other. The 802.11.x standards based wireless LANs support data rates from 1 Mbps to 54 Mbps. However, by IEEE 802.11.x standard, one access point (AP) can only cover an area of a few thousand square meters. It is perfectly applied for enterprise networks and public hot-spots such as hotels and airports. On the contrary, wireless cellular networks built with 3G standards can only support peak data transmission rates from 64Kbps to nearly 2 Mbps with a much wider area. It is reasonable and feasible to combine these two technologies to make Internet access much easier and more convenient.

The design of an **interworking** architecture to efficiently integrate **3G cellular** wireless networks and 802.11.x standard based wireless LANs is a challenge. Its difficulty lies in the objective of the integration, which is to achieve the seamless interoperation between the two types of the wireless networks with certain **QoS** guarantee and other requirements kept simultaneously, from the perspectives of both the end-users and the operators. There are basically two proposals as the solutions to the architecture of the integration. One is the tight coupling. The other is the loose coupling. Although there is no final selection on whether the future integrated network would use either of these techniques or another one, much focus of the research is on the loose coupling due to its feasibility.

To implement the integration based on the corresponding approach, there are a lot of issues needed to be addressed. They are the mobility management

for **vertical handoff**, the QoS maintenance during the vertical handoff, and the schemes of authentication, authorization and the accounting (**AAA**). In this article, we will focus on the issue of interworking architecture. The rest of the text is organized as follows. The second section will present the general ideas on the architecture of the integration of 3G cellular networks with wireless LANs. The third section will present several proposals on the architectures of the integration. At last, the fourth section will conclude the article.

## THE FRAMEWORK OF INTERWORKING ARCHITECTURE

The first important thing in the integration of 3G and wireless LAN is the development of concept architecture for 3G cellular and wireless LAN networks. This architecture should be able to support any type of user services in a secure and auditable way. Both user interfaces and interoperator interfaces must be clearly defined. And multiple service providers should be able to interoperate under the guidelines of this architecture. The users could choose the best available connection for the applications they are using at the active time.

Several approaches have been proposed for interworking networks architecture. The European Telecommunications Standards Institute (ETSI) specifies two generic approaches for interworking: loose-coupling and tight-coupling (Buddhikot, Chandranmenon, Han, Lee, Miller, & Salgarelli, 2003; Findlay, Flygare, Hancock, Haslestad, Hepworth, & McCann, 2002). The two candidate integration architectures are characterized by the amount of interdependence they introduce between the two component networks. On the other hand, the Third Generation Partnership Project (3GPP) (Ahmavaara, Haverinen, & Pichna, 2003; Salkintzis, 2004) has specified six interworking scenarios. The six

interworking scenarios provide a general and detailed picture on the transition from the loose-coupling to the tight-coupling interworking architecture.

### Tightly-Coupled Interworking

The rationale behind the tightly coupled approach is to make the wireless LAN network appear to the 3G core network as another 3G access network. The wireless LAN network would emulate the functions that are natively available in 3G radio access networks. Shown in the left side of Figure 1, to the upstream 3G core network, the wireless LAN gateway network element introduced to achieve integration appears to be a packet control function (PCF), in the case of a CDMA2000 core network, or to be a serving GPRS support node (SGSN), in the case of UMTS network. The wireless LAN gateway hides the details of the wireless LAN network to the 3G core, and implements all the 3G protocols including mobility management, authentication, and so forth, required in a 3G radio access network. Mobile nodes are required to implement the corresponding 3G protocol stack on top of their standard wireless LAN network cards and switch from one physical layer to another as needed. All the traffic generated by clients in the wireless LAN will be injected using 3G protocols into the 3G core network. These networks would share the same authentication, signaling, transport, and billing infrastructures independent from the protocols used at the physical layer on the radio interface.

### Loosely Coupled Approach

Like the tightly coupled architecture, the loosely coupled approach will also introduce a new element in the wireless LAN network, the wireless LAN gateway, as shown in the right side of Figure 1. The gateway connects to the Internet without direct link to 3G network elements such as packet data serving nodes (PDSN) or 3G core network switches. The users that could access services of the wireless LAN gateway include the local users that have signed on in a wireless LAN and the mobile users visiting from other networks. The data paths in wireless LANs and 3G cellular network have been completely separated. The high-speed wireless LAN data traffic is never injected into the 3G core network, but the end users can still experience seamless access. In this approach, different mechanisms and protocols,

which can interoperate for seamless operations, can handle authentication, billing, and mobility management in the 3G cellular and wireless LAN portions of the network. At the same time, the use of compatible AAA services on the two networks would allow the wireless LAN gateway to dynamically obtain per-user service policies from their home AAA servers. Then, it can enforce and adapt such policies to the wireless LAN network.

It is clear that the loose coupling offers several advantages over the tightly coupled approach with almost no drawbacks. It has emerged as a preferred architecture for the integration of wireless LANs and 3G cellular networks.

### Interworking Scenarios

The most intensive standardization activities are currently taking place in the Third Generation Partnership Project (3GPP), a standardization body that maintains and evolves the GSM and UMTS specifications. 3GPP has recently approved a WLAN/Cellular Interworking working team, which aims to specify one or more techniques for interworking between wireless LANs and GPRS networks (Ahmavaara et al., 2003; Salkintzis,

Figure 1. 3G and wireless LAN integration: Tightly coupled vs. loosely coupled architectures

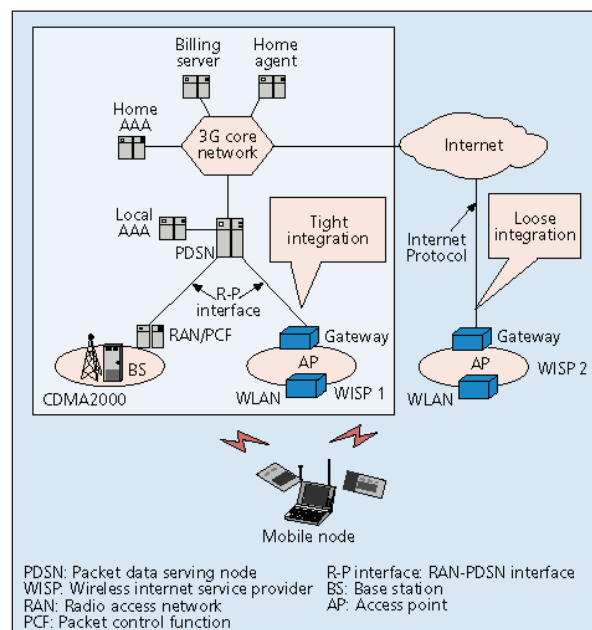

6 more pages are available in the full version of this document, which may be purchased using the "Add to Cart" button on the publisher's webpage: [www.igi-global.com/chapter/architectures-interworking-cellular-networks-wireless/17384](http://www.igi-global.com/chapter/architectures-interworking-cellular-networks-wireless/17384)

## Related Content

---

### Multimedia Social Network Modeling Using Hypergraphs

Giancarlo Sperli, Flora Amato, Vincenzo Moscato and Antonio Picariello (2018). *Digital Multimedia: Concepts, Methodologies, Tools, and Applications* (pp. 636-660).

[www.irma-international.org/chapter/multimedia-social-network-modeling-using-hypergraphs/189497](http://www.irma-international.org/chapter/multimedia-social-network-modeling-using-hypergraphs/189497)

### Using a Commodity Hardware Video Encoder for Interactive Applications

Håkon Kvale Stensland, Martin Alexander Wilhelmsen, Vamsidhar Reddy Gaddam, Asgeir Mortensen, Ragnar Langseth, Carsten Griwodz and Pål Halvorsen (2015). *International Journal of Multimedia Data Engineering and Management* (pp. 17-31).

[www.irma-international.org/article/using-a-commodity-hardware-video-encoder-for-interactive-applications/132685](http://www.irma-international.org/article/using-a-commodity-hardware-video-encoder-for-interactive-applications/132685)

### Leveraging Digital Multimedia Training for At-Risk Teens

Timothy Shea and Craig Davis (2008). *Multimedia Technologies: Concepts, Methodologies, Tools, and Applications* (pp. 1-1).

[www.irma-international.org/chapter/leveraging-digital-multimedia-training-risk/27155](http://www.irma-international.org/chapter/leveraging-digital-multimedia-training-risk/27155)

### PIR: A Domain Specific Language for Multimedia Information Retrieval

Xiaobing Huang, Tian Zhao and Yu Cao (2014). *International Journal of Multimedia Data Engineering and Management* (pp. 1-27).

[www.irma-international.org/article/pir/117891](http://www.irma-international.org/article/pir/117891)

### Media Literacy and Fake News: How Media Literacy Can Curb the Fake News Trend

Tracy Simmons (2018). *Handbook of Research on Media Literacy in Higher Education Environments* (pp. 255-268).

[www.irma-international.org/chapter/media-literacy-and-fake-news/204004](http://www.irma-international.org/chapter/media-literacy-and-fake-news/204004)