

Structural Synthesis of Universal Multiple-Valued Structures of Artificial Intelligence Systems

M.F.Bondarenko, A.V. Karpuhin, G.G. Chetverikov.
 State National University of Radio-Electronics;
 Ukraine, 61166, Kharkov, Lenin's avenue 14
 email: kav@kture.kharkov.ua

ABSTRACT

The basic construction concepts of many-valued intellectual systems which are adequate to primal problems of person activity and using hybrid tools with many-valued of coding are considered. The many-valued intellectual systems being two-place, but simulating neuron processes of space totting which are different on a level of actions, inertial and threshold of properties of neurons diaphragms, and also modification of frequency of following of the transmitted messages are created. All enumerated properties and functions in point of fact are essential not only are discrete on time, but also many-valued.

INTRODUCTION

The basic construction concepts of many-valued intellectual systems (MIS), which are adequate to primal problems of person activity and using hybrid tools with many-valued coding [1, 3] are considered. With materialism of a point of view these concepts are agreed with the dialectic laws opened by a man and their manifestations in problems connected with creation of identification systems prediction and recognition of imagery in which the interactive operational mode is a main part of the whole complex of intellectual properties.

Those are, for example, the law of unity and struggle of contrasts - as availability in parallel operating in space and time of mechanisms both discrete, and continuous map-ping objects of plants; the law of transition from quantitative changes to qualitative - quantitative changes of gradation levels of brightness and the colours result in qualitative changes in map-ping of objects; the law of negation of negation - as a changes and alternation of coding indications of messages about objects in neurons of a brain - from space to temporal and from two-place to many-valued [2].

In particular, in works the accent on the concept of neuro -physiologic and neuro - cybernetic aspects of alive brain mechanisms is made. It is connected with the following natural neuron structures from nervous cells - neurons, essentially are highly effective recognizing systems and, for this reason, is of interest not only for doctors and physiologists, but also for the experts designing artificial intelligence systems. However direct transfer of research results of neuro- physiologists in engineering practice is now impossible because of a lack of an appropriate bioelectronic technology and an element basis, that has led to development and creation of a set of varieties of artificial neurons realized on the elements of the impulse technology.

But also here there were complications because of non-adequate neuron models to a set of the demands made of "IS. Creation of neurolike models on the basis of multiprocessor in inputting systems technology with programmed architecture, in particular, on the basis of digital integrating structures is offered as the alternative in works [1, 3]. Thus, retaining Neumann structure a MIS are created, being essentially two-place, but simulating neuron processes of space totting different on a level of actions, inertial and threshold properties of neuron diaphragms, as well as variation of recurrence frequency of transmitted messages. Though it is obvious that all enumerated properties and functions in

point of fact, are, essential, not only discrete on time, but also many-valued (are discrete on a level).

As the corollary, non-adequacy of used principles of coding and element basis to simulated processes entails a redundancy, complication and non evidence of used mathematical and engineering means of transformations, loss of a micro level of parallelism in handling expected fast acting and flexibility of restructuring without essential modifications of architecture and connections.

STRUCTURALLY FUNCTIONAL CELL MODEL OF A MANY-VALUED INTELLECTUAL SYSTEM

The originating complications [1], in creation of a many-valued intellectual system (MIS) promote moving out of the adequacy concept of many-valued logic and structures to of MIS creation problems with desirable properties and possibilities.

Therefore for disclosure of use paths of a knowledge backlog in the field of many-valued coding and structures in MIS creation the conceptual structurally functional model of a MIS cell (Fig.1) is offered.

Each MIS is characterized by a set of functions fulfilled by it by blocks, which realize functions and information interchanges. In accordance with solved problems the structurally functional cell breaks up to three hierarchical levels: functional (analytic-synthetic) - level 1; tactical (analyses-coordination) - level 2; strategic (coordination) - level 3.

The MIS cell increases on a function level both on inputs, and on outputs, and it is integrated with other meshes on inputs of decoders of intermediate indications; at a tactical level - through the analyze - coordination processor; at a strategic level - through the processor - supervisor and knowledge base. The conceptual model of a MIS cell is based on the concept of symbiosis of two- and many-valued tools of data processing, therefore at a strategic level it contain complexes of converters of the data representation form - converters from a two-place code to many-valued ($2 \rightarrow k$) and back ($k \rightarrow 2$). Obviously, that their use in MIS determines, at what level the problems, are solved in what logic and with what speed (what channel capacity of MIS). Besides the application of these tools excludes necessity of an operator work with two-place translators in input - output of data.

Fig. 1. A conceptual structurally functional model of a MIS cell

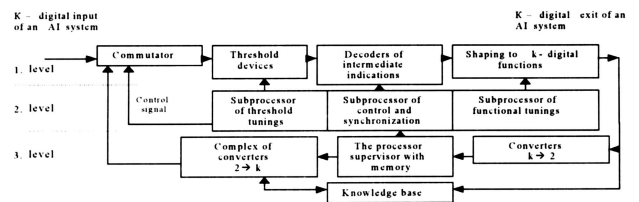

The new principle of the COMPUTER construction is offered, in which the principle of organization of brain work simultaneously with a principle of programmed control assumes as a basis. The principle of organization of brain work assumes as a basis of operation of such COMPUTERS, in classical element basis it will be for more to Hilbert machines than for nowadays existing Neumann machines, the basis of which is the principle of programmed control realized rather slowly.

FORMALIZATION OF CONSTRUCTION PRINCIPLES OF MANY-VALUED SPATIAL STRUCTURES

In the generalized form the two-input universal k-valued structure of a spatial type contains two recognition elements (RE), the control unit (CU), the matrix selector (MS), commutator (C), and keys (K) or the digital-to-analog converter (DAC) [3] (Fig.2).

The logic of the decoders operation in recognition elements 1,2 is described by the following equation system:

$$f_0 = (x_0, x_{1,\dots}, x_{k-1}) = y^0,$$

$$f_0 = (x_0, x_{1,\dots}, x_{k-1}) = y^1,$$

.....

$$f_0 = (x_0, x_{1,\dots}, x_{k-1}) = y^{k-1}.$$

or in the explicit form at the algebra language of finite predicates [1]:

$$y_{1,2}^0 = \overline{x_1},$$

$$y_{1,2}^1 = x_1 \wp x_2,$$

$$y_{1,2}^2 = x_2 \wp x_3,$$

.....

$$y_{1,2}^{k-1} = x_{k-1}.$$

where x_i and $\overline{x_i}$ ($i = \overline{0, k-1}$) – signals of direct and inversion outputs of the ADC units in recognition elements 1,2. The logic of the matrix selector is described by the following equation system:

$$b_{10} = y_1^1 \wp y_2^0, b_{11} = y_1^1 \wp y_2^1, \dots, b_{1(k-1)} = y_1^1 \wp y_2^{k-1}$$

.....

$$b_{(k-1),0} = y_1^{k-1} \wp y_2^0, \dots, b_{(k-1)(k-1)} = y_1^{k-1} \wp y_2^{k-1}$$

where b_{ij} ($i, j = \overline{0, k-1}$) – output logical signals of the matrix selector. The commutator has two groups by k inputs: the signals from the selector are applied to the first group and control signal values are, applied to the second group. In the explicit from the commutator operation is described by the following system:

$$b^{k0} 1^0 \vee b^{k0} 1^1 \vee \dots \vee b^{k0} 1^{k-1} = z^{k0},$$

$$b^{k1} 1^0 \vee b^{k1} 1^1 \vee \dots \vee b^{k1} 1^{k-1} = z^{k1},$$

.....

Fig. 2. Universal multiple-valued functional converter

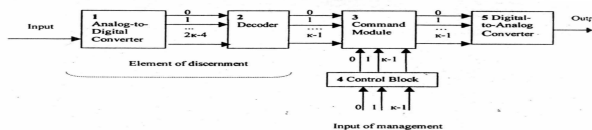

$$b^{k_{k-1}} 1^0 \vee b^{k_{k-1}} 1^1 \vee \dots \vee b^{k_{k-1}} 1^{k-1} = z^{k_{k-1}}.$$

As all k of keys of the output shaper are constantly connected to corresponding k-values of output signals the function values selected by the commutator and the control unit, respectively, will arrive in the converter output (structure) in the course of variations of k-valued functions on the converter inputs. The process control of the logic recomputations is carried out under the action of external control signals.

MODELLING AND REALIZATION

One of ways of realization of multiple-valued elements is the frequency - harmonic multi - state element, which basis is the self - excited oscillator with a nonlinear resonant circuit, which is synchronized by an external voltage source.

The authors offer one of variants of self - excited oscillator (Fig.3.)

At apparent simplicity such circuit due to nonlinear properties has a lot of stable states. This circuit is supplied by a sequence of pulses with high period-to-pulse duration ratio. The control of circuit is carried out by feed of control pulses in a circuit of automatic bias. In result capacity

C_ϕ is charged, the voltage of bias on p-n junction is increased, that results in increase of resonant frequency of a resonant circuit. The process comes to an end then, when the resonant circuit appears tuned on next harmonic of a supplied voltage. Besides, the voltage of automatic bias changes too. Thus, the multi - state element has two attribute of each stable state - a voltage and frequency.

Using parabolic approximation of the characteristic of the transistor, we shall receive the following equation for a charge on nonlinear capacity of p-n junction

$$\begin{aligned} \frac{d^2 \vartheta}{dt^2} + \omega^2 \overline{\vartheta} = & -\xi \frac{d\vartheta}{dt} - \frac{\omega^2}{2} \vartheta - \varepsilon [s_0^* + 2s_1^* E_1 \cos vt] \frac{v E_1 \sin vt}{2\phi_k (1+b)} - \\ & - 2\varepsilon (1 + \vartheta) s_1^* v \vartheta E_1 \sin vt + 2\varepsilon (1 + \vartheta) s_1^* \frac{d\vartheta}{dt} E_1 \cos vt + \\ & + \varepsilon [s_0^* + s_1^* \vartheta + 4\lambda \vartheta + 2\lambda \vartheta^3 + 6\lambda \vartheta^2] \frac{d\vartheta}{dt}, \end{aligned}$$

Fig. 3.

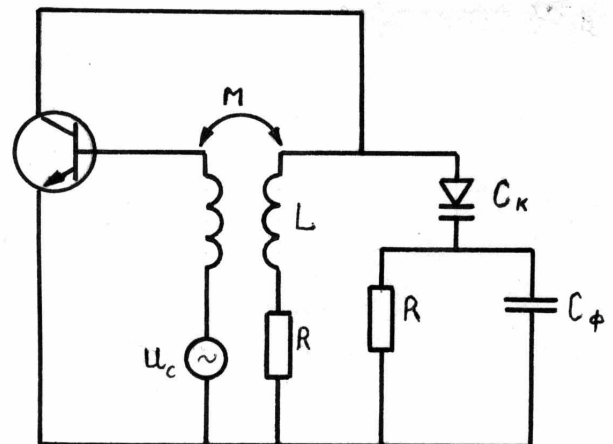

where $\vartheta = \frac{q}{2C_k(E + \varphi_k)}$ - normalized charge on capacity of p-n junction;

ω - resonant frequency of a resonant circuit; $\xi = \frac{1}{RC_k}(1 + \varepsilon)$ - equivalent

decrement coefficient; $\varepsilon = \frac{M}{L} \frac{1}{\mu}$ - small parameter; M - mutual inductance; L - inductance; μ - amplification factor of the transistor ;

$$C_k = C_{k0}(1 + b)^2; s_0^* = \frac{s_1}{C_k}; s_2^* = s_0^* + \frac{\xi}{\varepsilon}; \lambda = s_1^* \varphi_k (1 + b);$$

S_0, S_1 - coefficients of polinomial in approximation of

the characteristic of the transistor; φ_k - contact difference of poten-

tials; $b = \frac{E}{\varphi_k}$ - normalized voltage of bias on p-n junction; ν - frequency

of a synchronizing signal; E_1 - amplitude of a synchronizing signal.

The solution of the this equation in the second approximation in case of the main resonance is

$$\begin{aligned} \vartheta = & a \cos(\nu t + \nu) + \frac{\varepsilon}{6\nu} a^2 (s_2^* + \lambda + \lambda a^2) \sin 2(\nu t + \nu) + \\ & + \frac{\varepsilon a s_1^* E_1}{6\nu} (\sin \nu + \cos \nu) \sin(\nu t + \nu) - \frac{\varepsilon a s_1^*}{3\nu} \sin \nu \cos 2(\nu t + \nu) + \\ & + \frac{1}{48} \varepsilon a^3 s_2^* (7 - 2a); \end{aligned}$$

$$\begin{aligned} \frac{da}{dt} = & -\frac{1}{2} \left[Z a + \frac{1}{48} \varepsilon a^3 s_2^* (7 - 2a) \right] + \frac{\varepsilon}{2} W \cos \nu; \\ \frac{d\nu}{dt} = & \omega - \nu + \frac{1}{8\omega} (\xi - \varepsilon s_0^* - \frac{9}{4} \varepsilon \lambda a^2) Z + \frac{\varepsilon^2 a^2}{24\omega} (s_2^* + \lambda + \lambda a^2) \times \\ & \times (s_2^* + 4\lambda) + \frac{\varepsilon^2 a^4 \lambda}{8\omega} (s_2^* + \lambda) + \frac{\varepsilon s_0^*}{4\omega} Z + \frac{9\varepsilon \lambda}{8\omega} a^2 Z - \frac{\varepsilon}{2a} W \sin \nu; \\ Z = & \xi - \varepsilon s_0^* - \frac{3}{4} \varepsilon \lambda a^2; W = \left[\frac{s_0^*}{2\varphi_k(1+b)} + a^2 s_1^* \right] E_1. \end{aligned}$$

Let's consider conditions, at which the stable synchronous mode of stationary oscillations is possible. The values of amplitude and phase in a stationary mode are determined from system of the equations

$$R(a, \nu) = 0; T(a, \nu) = 0, \tag{2}$$

where $R(a, \nu), T(a, \nu)$ - right parts of the equations (1).

The conditions of stability of the solutions of the equations (2) are determined by the following inequalities

$$\left. \frac{da}{d\nu} \right|_0 \omega_e(a) > \nu;$$

$$\left. \frac{da}{d\nu} \right|_0 \omega_e(a) < \nu,$$

where $\omega_e(a)$ - equivalent frequency of own oscillations.

The analysis of phase portraits of this dynamic system (frequency - harmonic multi - state element) has confirmed presence of stable modes in it.

By excluding a phase from the equations (2) it is possible to receive the equation for the amplitude - frequency characteristic.

The considered above frequency - harmonic multi - state element was realized as the thin-film integrated circuit. The problem of it optimization [4] was solved.

The earlier received results get the importance in this time, when the semiconductor technology of manufacturing of the large scale integrated circuits for microprocessors practically has reached a physical limit of reduction of the size of components and width of interconnections. Alternative can be only use of artificial intelligence systems, in which the elements of multiple-valued logic can be used. Experimental samples of the frequency - harmonic multi - state element were realized as thin-film integrated circuits in the standard case and can be used as elements of multiple-valued logic .

CONCLUSION

The problem solving of principles formalization of the structure organization of computing tools, thus ensures construction of the newest concept for systems of an artificial intelligence; application of space and temporal parallelism at structural and algorithmic levels; creation of procedural and functional languages, parallel machines of knowledge bases and the inference. The problem solving of organization principles formalization of universal k-valued structures of a spatial type by tools of predicate and hybrid logic will ensure construction of a modern concept for artificial intelligence systems, application of spatial parallelism at structured and algorithmic levels; creation of functional languages of parallel machines of knowledge basis; application of symbiosis of two- and many-level heterogeneous coding.

One of circuit for realization of multiple-valued elements is the frequency - harmonic multi - state element which states are coding by amplitude and frequency. This element can be made by thin film technology.

REFERENCES

[1] M.F. Bondarenko, Z.D. Konopljanko, G.G. Chetverikov, "Osnovy teorii synteza nadshvydkodiuchikh structur movnykh sistem shtuchnogo intellektu", Monografia - K.: IZMN, 1997. - 386 s.
 [2] М.Ф.Бондаренко,С.В.Ляховець,О.В.Карпухин,Г.Г.Четверіков.Синтез швидкодіючих структур лінгвістичних об'єктів.Труды X Международной конференции «ЗНАНИЕ-ДИАЛОГ-РЕШЕНИЕ» (KDS-2001)/Спб,2001.-с 121-129.
 [3] M.F. Bondarenko, V.N. Bavykin, I.A. Revenchuk, G.G. Chetverikov, "Modeling of universal multiple-valued structures of artificial intelligence systems", Proc. of the 6th International Workshop "MIXDES'99", Krakow, Poland, 17-19 June 1999, pp. 131-133.
 [4] Яловега Г.И., Лоза Ю.Х., Карпухин А.В. Математическое моделирование и оптимизация многофункциональных резонансных цепей.26.Internationales Wissenschaftliches Kolloquim.Technische Hochschule Ilmenau,1981,Heft 2,Vortragsreihen A3, A1.

0 more pages are available in the full version of this document, which may be purchased using the "Add to Cart" button on the publisher's webpage:

www.igi-global.com/proceeding-paper/structural-synthesis-universal-multiple-valued/31988

Related Content

Sheaf Representation of an Information System

Pyla Vamsi Sagarand M. Phani Krishna Kishore (2019). *International Journal of Rough Sets and Data Analysis* (pp. 73-83).

www.irma-international.org/article/sheaf-representation-of-an-information-system/233599

Trend-Aware Data Imputation Based on Generative Adversarial Network for Time Series

Han Li, Zhenxiong Liu, Jixiang Niu, Zhongguo Yangand Sikandar Ali (2023). *International Journal of Information Technologies and Systems Approach* (pp. 1-17).

www.irma-international.org/article/trend-aware-data-imputation-based-on-generative-adversarial-network-for-time-series/325212

Classification Reasoning as a Basic Part of Machine Learning

Xenia Naidenova (2015). *Encyclopedia of Information Science and Technology, Third Edition* (pp. 114-121).

www.irma-international.org/chapter/classification-reasoning-as-a-basic-part-of-machine-learning/112321

An Analytics Architecture for Procurement

Sherif Barrad, Stéphane Gagnonand Raul Valverde (2020). *International Journal of Information Technologies and Systems Approach* (pp. 73-98).

www.irma-international.org/article/an-analytics-architecture-for-procurement/252829

Symmetry Detection in Brain Image Analysis

Surani Anuradha Jayasuriya, Alan Wee-Chung Liewand Phillip Sheridan (2015). *Encyclopedia of Information Science and Technology, Third Edition* (pp. 5615-5623).

www.irma-international.org/chapter/symmetry-detection-in-brain-image-analysis/113015